

400 W. Artesia Blvd.
Compton, CA 90220
Fax: (310) 747-3912
Ph: 1-800-776-0767
E-Mail: info@procompusa.com
Website: www.procompusa.com

Latest Revision:
8.25.2021



PRO COMP SUSPENSION

K2197B/ BP/ T/ M

56753B

6" 2014 & Up Ram 2500 4X4 Gas Radius Arm Drop kit

K2198B/ BP/ T/ M

56753B

6" 2014 & Up Ram 2500 4X4 Diesel Radius Arm Drop kit

This document contains very important information that includes warranty information and instructions for resolving problems you may encounter. Please keep it in the vehicle as a permanent record.

Box 1 of 4-PN # 56717B-1

Part #	Description	Qty.	Illus.	Page
90-9540	1/2" NARROW NUT PLATE	4		
90-6502	HARDWARE PACK: Radius Arm Drop	2	-	-
50C125HCS8Y	1/2" X 1 1/4" HEX BOLT Gr. 8	2	3	8
50NWHDY/SAE	1/2" HARDENED FLAT WASHER	2	3	8
91-9542	RADIUS ARM DROP	2	3	8
90-6953	HARWARE PACK: Radius Arm Drop	1	-	-
	18mm-1.5 X 120mm HEX BOLT Gr. 10.9	2	3	8
	18mm-1.5 STOVER NUT Gr. 10.9	2	3	8
	18mm FLAT WASHER	4	3	8

Box 2 of 4 PN # 56717B-2

DC600-1	PITMAN ARM	1	4	9
96-5779	PITMAN ARM TORQUE TOOL	1	4	9
HERNON427	RED THREAD LOCKER	1	-	-
15-10995	BUMPSTOP	2	2	7
90-6029	HARDWARE PACK: Front Brake Line	1	-	-
15-10966	3/8" PLASTIC HOSE CLAMPS	4	-	-
13-20447	#10 X 1/2" HWH ZINC	4	-	-
91-3081	REAR BUMP STOP BRACKETS	4	A	16
90-6223	HARDWARE PACK: Rear Bump Stops	1	-	-
70-0371251800	3/8" X 1 1/4" HEX BOLT GR. 8	4	A	16
72-0371000816	3/8" STOVER NUT	4	A	16
73-03700034	3/8" SAE FLAT WASHER Gr. 8	8	A	16
90-6340	HARDWARE PACK: Sway Bar Drops	1	7	12
70-0431251800	7/16" X 1 1/4" HEX BOLT Gr. 8	4	7	12
72-043100816	7/16" STOVER NUT	4	7	12
73-0400830	7/16" FLAT WASHER	8	7	12
91-9523	SWAY BAR DROP: Drvr	1	7	12
91-9526	SWAY BAR DROP: Pass	1	7	12
90-9528	BRAKE LINE TAB: Drvr	1	8	12
90-9529	BRAKE LINE TAB: Pass	1	8	12
90-6958	HARDWARE PACK: Front Brake Line Tabs	1	8	12
90-4591	8mm-1.25 CLIP-ON NUT	2	8	12
90-6299	HARDWARE PACK: Front Brake Line Tabs	1	8	12
70-0311001800	5/16" X 1" HEX BOLT GR. 8	2	8	12

Part #	Description	Qty.	Illus.	Page
72-0531100816	5/16" NYLOCK NUT	2	8	12
73-03100034	5/16" HARDENED FLAT WASHER	4	8	12
91-10914	FRONT TRACK BAR DROP BRACKET	1	9	13
35-10918	SPACER: Front Track Bar Bracket	1	9	13
90-8321	TRACK BAR BRACKET SPACER	1	9	13
90-6954	HARDWARE PACK: Track Bar Bracket to Frame	1	9	13
	18mm- 1.5 X 100mm HEX BOLT Gr. 10.9	1	9	13
	18mm- 1.5 STOVER NUT 10.9	1	9	13
	18mm FLAT WASHER PLATED	2	9	13
90-9536	3/8" DOUBLE NUT PLATE: Track Bar Bracket	1	9	13
90-6955	HARDWARE PACK: Track Bar Bracket	1	9	13
	3/8" X 1 1/4" HEX BOLT Gr. 8	2	9	13
	3/8" FLAT WASHER PLATED	2	9	13
90-6956	HARDWARE PACK: Cam Bolt	1	9	13
90-4583	CAM BOLT: 100mm	1	9	13
90-9539	CAM WASHER	1	9	13
72-01815010912	18mm-1.5 NUT: 10.9	1	9	13
73-01800040	18mm WASHER PLATED	1	9	13
73-01800036	18mm SPLIT-LOCK WASHER	1	9	13
97-10420	COIL SPRING ISOLATOR DRILL TEMPLATE	1	-	-
Box 3 of 4 PN # 56753B-3				
927591	FRONT SHOCK ABSORBER	2	5	10
926553	REAR SHOCK ABSORBER	2	-	-
Box 927553B/ 926553B (K2097T/ 98T)				
927553B	FRONT SHOCK ABSORBER	2	-	-
926553B	REAR SHOCK ABSORBER	2	-	-
Box PR2116/ PR2117 (K2097M/ K98M)				
PR2116	FRONT SHOCK ABSORBER	2	-	-
PR2117	REAR SHOCK ABSORBER	2	-	-
Box 3 of 4 PN # 56753B-4				
91-2311	SWAY BAR END LINK	2	13	17
45359	BUSHINGS	4	13	17
60859H	SLEEVE	4	13	17

Part #	Description	Qty.	Illus.	Page
90-6803	HARWARE PACK: Rear Sway Bar	2	-	-
.12C65H10I/DIN931	12mm-1.75 X 65mm HEX BOLT 10.9	1	13	17
.12CNPTZ/DIN980V-CL10	12mm-1.75 NYLOCK NUT	1	13	17
.12RWFLI/HV200-125	12mm FLAT WASHER	2	13	17
90-6967	HARWARE PACK: Rear Sway Bar	1	-	-
.12C75H10Z/DIN931	12mm-1.75 X 75mm HEX BOLT 10.9	2	13	17
.12CNPTZ/DIN980V-CL10	12mm-1.75 NYLOCK NUT	2	13	17
.12RWHDZ	12mm HARDENED FLAT WASHER	4	13	17
90-6962	HARWARE PACK: Rear Sway Bar	1	-	-
	12mm USS FLAT WASHER	4	13	17
90-8322	TRACK BAR CRUSH SLEEVE	1	12	16
91-9554	REAR TRACK BAR RELOCATION BRACKET	1	12	16
91-9555	REAR COIL SPACER BRACKET: Drvr	1	10	15
91-9561	REAR COIL SPACER BRACKET: Pass	1	11	16
91-9566	REAR COIL SPACER	4	-	-
90-6963	HARWARE PACK: Coil Spacer Bracket	1	-	-
56C400HC8I/IMP	9/16" X 4" HEX BOLT	1	12	16
56CNPTZ/GRC	9/16" TOPLOCK Gr. C	1	12	16
56RWHDII/IMP	9/16 HARDENED FLAT WASHER	2	12	16
90-6892	HARWARE PACK: Coil Spacer Bracket	1	-	-
43C125HC8I/IMP	7/16" X 1 1/4" HEX BOLT Gr. 8	2	10	15
43CNPTZ/GRC	7/16" NYLOCK NUT Gr. C	2	10	15
43RWHDII/IMP	7/16" HARDENED FLAT WASHER	4	10	15
90-6944	HARWARE PACK: Coil Spacer Bracket	1	-	-
37C100HC8I/IMP	3/8" X 1 HEX BOLT Gr. 8	1	10,11	15,16
37CNNLZ	3/8" NYLOCKNUT	1	10,11	15,16
37RWHD\$/IMP	3/8" HARDENED FLAT WASHER: BLACK	2	10,11	15,16
90-6223	HARWARE PACK: Coil Spacer Bracket	1	-	-
37C125HC8I/IMP	3/8" X 1 1/4 " HEX BOLT Gr. 8	4	10,11	15,16
37CNPTZ/GRC	3/8" NYLOCK NUT Gr. C	4	10,11	15,16
37RWHDII/IMP	3/8" HARDENED FLAT WASHER	8	10,11	15,16

**FOLLOWING PARTS ARE USED IN CONJUNCTION WITH THIS KIT.
THEY ARE PACKAGED AND MUST BE ORDERED SEPARATELY.**

**COIL SPRINGS: 56190 x1 & 91-10763B x1 (Gas) For 2014 6" kit
COIL SPRINGS: 56180 x1 & 91-10763B x1 (Diesel) For 2014 6" kit**

Optional Equipment Available from your Pro Comp Distributor!

50328

U-bolt kit for vehicles w/ Dana 80 rear axle.

Check out our outstanding selection of Pro Comp tires to compliment your new installation!

- ⇒ Front end and head light realignment is necessary!
- ⇒ Speedometer and ABS recalibration will be necessary if larger tires (10% more than stock diameter) are installed.

TIRE INFORMATION:

Tire and wheel choice is crucial in assuring proper fit, performance, and the safety of your Pro Comp equipped vehicle. For this application, a wheel not to exceed 10” in width with a minimum backspacing of 3.25” must be used. Additionally, a quality tire of radial design, not exceeding 37” tall X 13.5” wide is recommended. Violation of these recommendations will not be endorsed as acceptable by Pro Comp Suspension and will void any and all warranties either written or implied.

SPECIAL TOOLS:

- ⇒ PLEASE REFER TO YOUR SERVICE MANUAL FOR MORE INFORMATION.
- ⇒ A SPECIAL REMOVAL TOOL IS REQUIRED FOR SAFE REMOVAL OF THE TIE RODS.
- ⇒ A SPECIAL REMOVAL TOOL IS REQUIRED FOR SAFE REMOVAL OF THE COIL SPRINGS.
- ⇒ YOU WILL NEED TO PURCHASE NEW FACTORY CAM BOLTS FOR THE LOWER CONTROL ARMS.
- ⇒ THESE TOOL MAY BE PURCHASED AT YOUR LOCAL DEALER.
- ⇒ YOU MAY BE ABLE TO RENT ANY OF THESE TOOLS AT YOUR LOCAL PARTS STORE.

Introduction:

- ◆ This installation requires a professional mechanic!
- ◆ We recommend that you have access to a factory service manual for your vehicle to assist in the disassembly and reassembly of your vehicle. It contains a wealth of detailed information.
- ◆ Prior to installation, carefully inspect the vehicle's steering and driveline systems paying close attention to the tie rod ends, wheel bearing preload, pitman and idler arm. Additionally, check steering-to-frame and suspension-to-frame attaching points for stress cracks. The overall vehicle must be in excellent working condition. Repair or replace all worn or damaged parts!
- ◆ Read the instructions carefully and study the illustrations before attempting installation! You may save yourself a lot of extra work.
- ◆ Check the parts and hardware against the parts list to assure that your kit is complete. Separating parts according to the areas where they will be used and placing the hardware with the brackets before you begin will save installation time.
- ◆ Check the special equipment list and ensure the availability of these tools.
- ◆ Secure and properly block vehicle prior to beginning installation.
- ◆ ALWAYS wear safety glasses when using power tools or working under the vehicle!
- ◆ Use caution when cutting is required under the vehicle. The factory undercoating is flammable. Take appropriate precautions. Have a fire extinguisher close at hand.
- ◆ Foot pound torque readings are listed on the Torque Specifications chart at the end of the instructions. These are to be used unless specifically directed otherwise. Apply thread lock compound where specified.
- ◆ **Please note that while every effort is made to ensure that the installation of your Pro Comp lift kit is a positive experience, variations in construction and assembly in the vehicle manufacturing process will virtually ensure that some parts may seem difficult to install. Additionally, the current trend in manufacturing of vehicles results in a frame that is highly flexible and may shift slightly on disassembly prior to installation. The use of pry bars and tapered punches for alignment is considered normal and usually does not indicate a faulty product. However, if you are uncertain about some aspect of the installation process, please feel free to call our tech support department at the number listed on the cover page. We do not recommend that you modify the Pro Comp parts in any way as this will void any warranty expressed or implied by the Pro Comp Suspension company.**
- ◆ Disconnect the negative battery cable when working on the vehicle.

Front Installation

1. Prior to installing this kit. With the vehicle on the ground, measure the height of your vehicle. This measurement can be recorded from the center of the wheel, straight up to the top of the inner fender lip. Record the measurements below.

LF: _____ RF: _____

LR: _____ RR: _____

2. Ensure that your work space is of adequate size and the work surface is level. Set the emergency brake. Place your floor jack under the front axle and raise vehicle. Place jack stands under the frame rails behind the front wheel wells and lower the frame onto the stands. Remove the jack and place blocks both in front of and behind the rear wheels. Remove the wheels.
3. Remove any skid plates or debris shields from the bottom of the vehicle.
4. Unbolt both brake line brackets from the axle and front axle brackets to allow for free movement of the suspension components.
5. Unbolt the sway bar from the end links and remove it from the vehicle. Save the

sway bar and hardware for reinstallation.

6. Unbolt and remove the front track bar from the vehicle. Save the **OE** bolts and hardware for reuse
7. Unbolt and remove the front shock ab-

Work on one side of the vehicle at a time.

sorber. Save the **OE** hardware for reinstallation.

8. Carefully lower the floor jack until coil spring is free from the upper spring pocket. Remove the coil spring.
9. Remove and set aside the upper and lower rubber isolator pads for the coil.
10. Repeat on other side of the vehicle.
11. Locate the front rubber bump stops, mounted on the frame near the coils. Remove the bump stop from it's pocket using a pair of pliers. A back and forth action will assist in working it out.
12. Place the new bump stops (**15-10995**) in existing bump stop pockets, as shown in **ILLUSTRATION 2**. By using leverage against the bottom of the bump stops, force the bump stop into place (detergent soap may help if the fit is tight).

NOTE: Use the weight of the vehi-

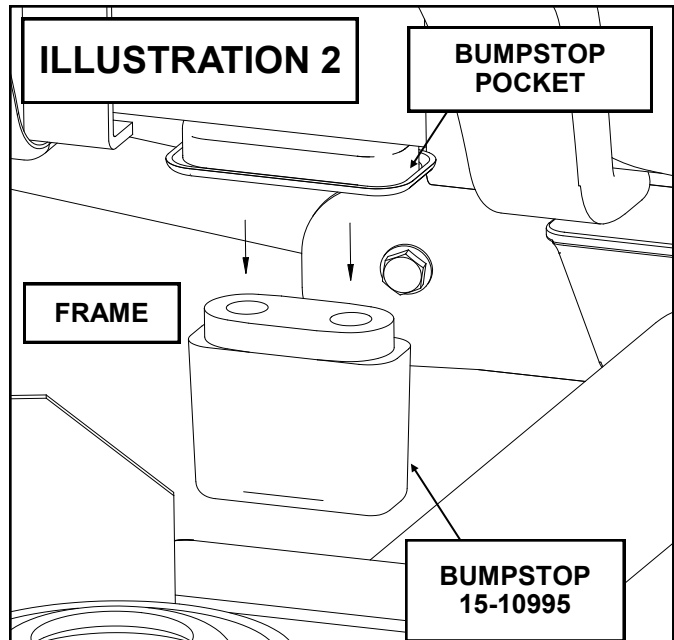
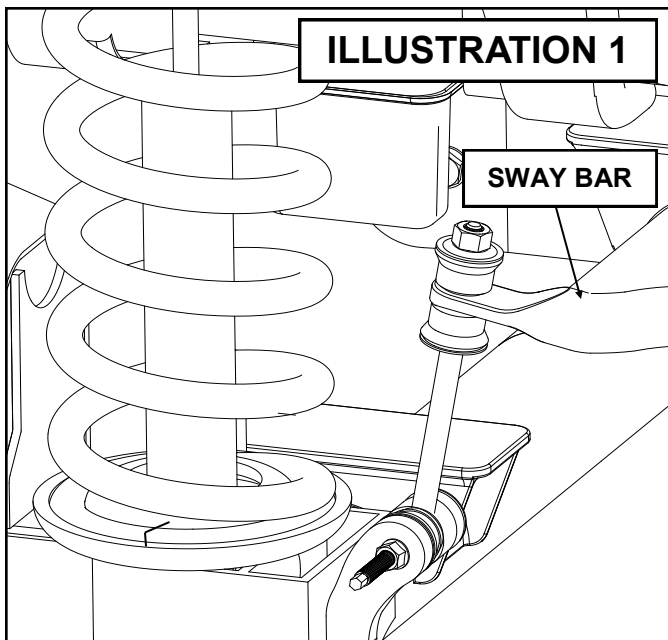

cle to help set the bump stops in place.

13. Using a jack, support the radius arm at the frame mount.
14. Remove the **OE** bolts from both **OE** lower radius arm mounts. Save the **OE** hardware for reinstallation.
15. Lower the **OE** radius arm from the frame pocket to provide adequate clearance to insert the radius arm drop (**91-9542**) into

the frame pocket. See **ILLUSTRATION 3**.

16. Use the supplied **18mm X 120mm** bolt to secure the radius arm drop (**91-9542**) to the frame. Use the previously removed **OE** nut plate on the upper bolt. See **ILLUSTRATION 3**.
17. Feed the **1/2"** narrow nut plates (**90-9540**) through the existing holes in the frame and secure the front and rear of

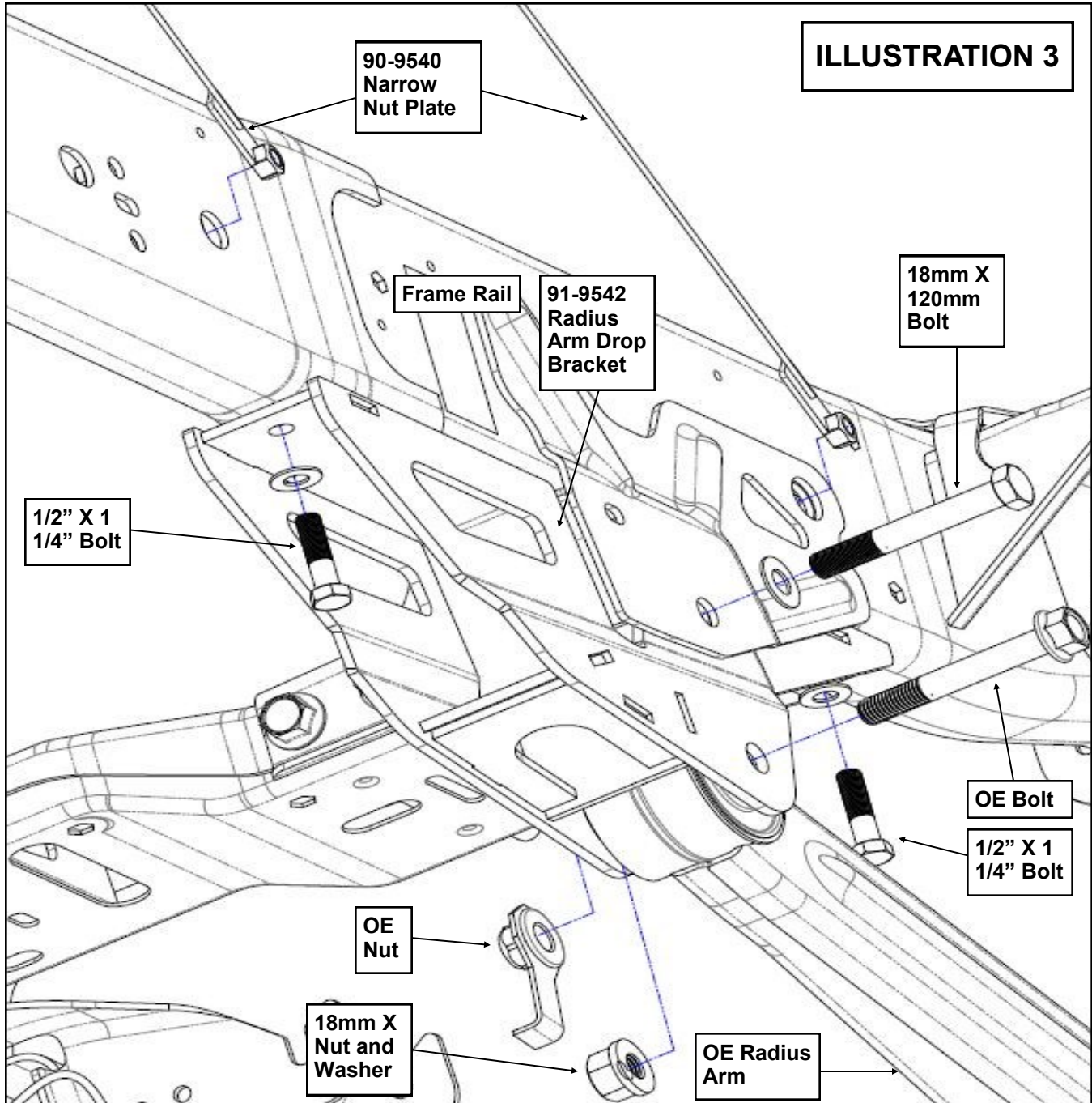

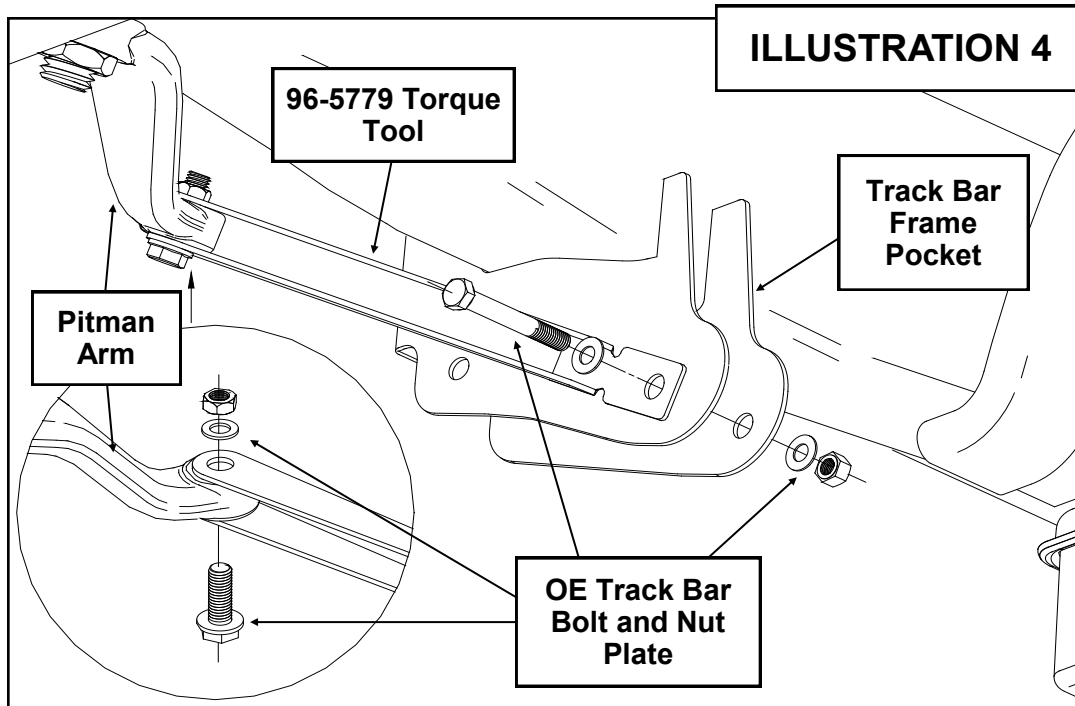

the radius arm drops to the frame pocket using the supplied **1/2" X 1 1/4"** bolts and hardware. See **ILLUSTRATION 3**.

18. Raise the radius arms up into the new drops and secure using the previously removed **OE** bolts and hardware. See **ILLUSTRATION 3**.
19. Torque all radius arm drop hardware at this time according to the chart on page **19**. **DO NOT** torque the **OE** radius arm bolts until vehicle is resting on the ground at ride height.
20. Remove the sector shaft Pitman arm retaining nut and save for reinstallation. Use a Pitman arm puller to remove the **OE** pitman arm. The threads of the sector shaft and the Pitman arm retaining nut must be cleaned of all factory dry adhesive.

IMPORTANT!: THE ENTIRE INSTALLATION PROCESS MUST BE DONE WITH HAND TOOLS TO ENSURE PROPER INSTALLATION. DO NOT USE IMPACT TOOLS.

21. Install new pitman arm on sector shaft. Oil the sector shaft threads to ensure a proper torque reading. Install Pitman arm retaining nut and tighten until snug.

22. Insert the key and unlock the steering wheel.

23. Install the Pitman arm torque tool (**96-5779**) to the Pitman arm using one of the previously removed **OE** track bar bolt and nut plate. See **ILLUSTRATION 4**.

24. Secure the torque tool (**96-5779**) to the existing hole in the track bar frame mounting pocket using one of the previously removed **OE** track bar bolt and nut plate. See **ILLUSTRATION 4**.

NOTE: The steering wheel may need to be turned in order for the hole in the torque tool and the frame cross-member to line up. Once the bolts are tightened the torque tool will align it's self properly.

NOTE: The use of the torque tool is to keep the Pitman arm from moving right or left, but allow for movement up the sector shaft. If you do not have this tool, a length of chain or a flat bar with two holes is a suitable replacement.

25. Torque the Pitman arm retaining nut to **225** ft./lbs.

26. With the torque tool (**96-5779**) still in place remove the pitman arm retaining nut. The threads of the sector shaft and

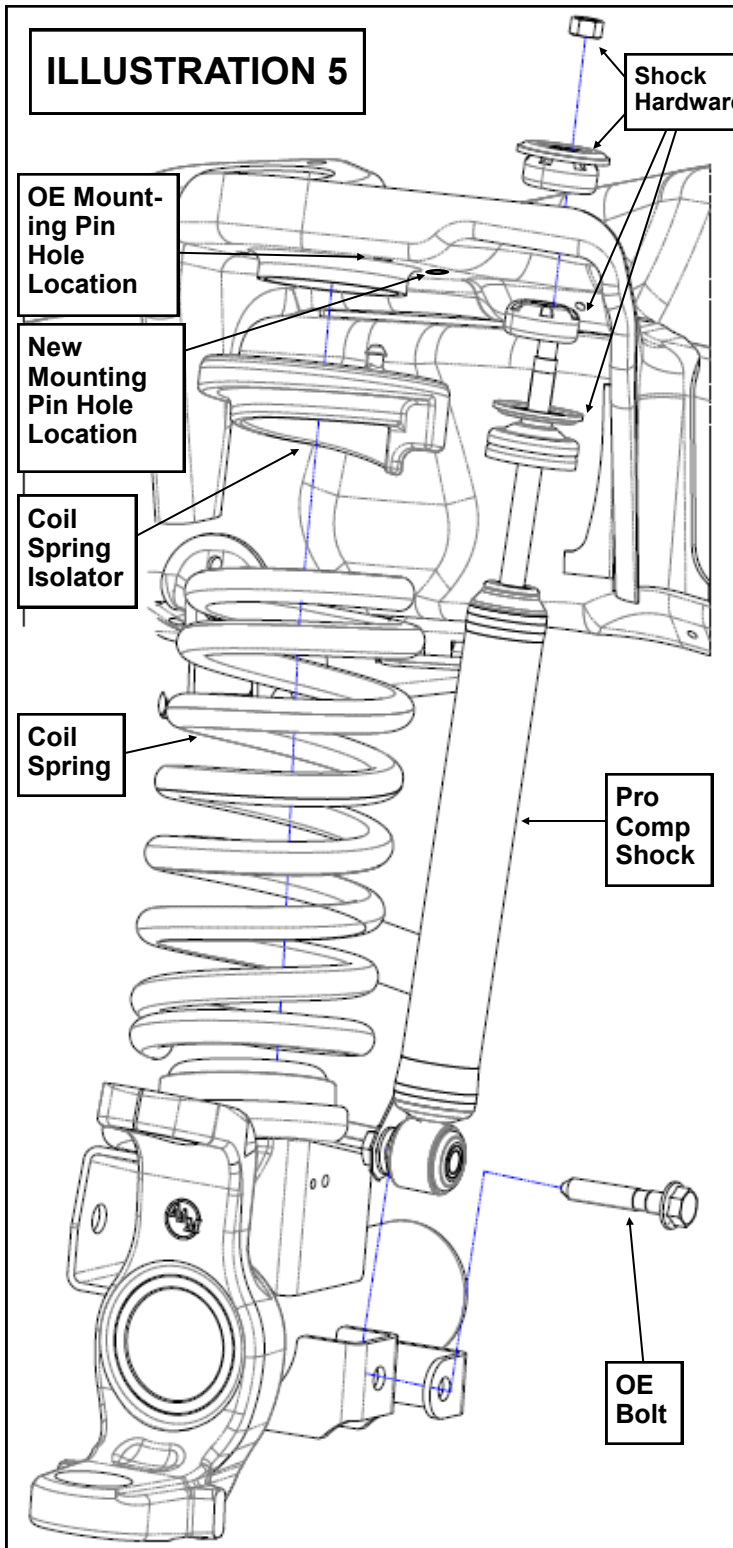

the Pitman arm retaining nut ***MUST*** be cleaned using brake cleaner or another suitable method to remove the previously applied oil.

27. Use the entire supplied thread locking compound to thoroughly cover the entire surface of the threads on the Pitman arm retaining nut.
28. Reinstall the Pitman arm retaining nut to the sector shaft and torque to **225 ft./lbs.**
NOTE: Whether re-using the existing pitman arm retaining nut or replacing with a new nut, thread locking compound must be used.
29. Unbolt and remove the Pitman arm torque tool (**96-5779**) from the vehicle.
NOTE: Save this Pitman arm torque tool to add to your toolbox for any future Pitman arm installations.
30. Insert the factory spring isolator drill template (**97-10420**) into the upper coil spring mounting bucket. Locate the drill template by aligning the hole marked **OEM** hole location, on the drill template, with the **OE** hole in the upper coil spring mounting bucket.
31. Mark and center punch the new coil spring isolator mounting pin hole location for drilling.
NOTE: The newly drilled isolator pin locating hole will be 90 degrees from the original hole.
32. Drill out the previously applied mark using a **1/2"** Drill bit.
33. The front coil springs (**56190 x1 & 91-10763B x1 6" gas, or 56180 x1 & 91-10763B x1 6" diesel**) have a top to bottom orientation. The bottom of the coil (axle pad) will sit on a flat surface and stay upright.
IMPORTANT!: Be certain that you are installing the coils correctly.
34. Install the factory spring isolator onto the supplied Pro Comp coil springs. Raise the front axle, spring and isolator into place and make sure the isolator locating pin is in the newly drilled hole. Repeat for the other side. See **ILLUSTRATION 5.**

NOTE: The printed part number on

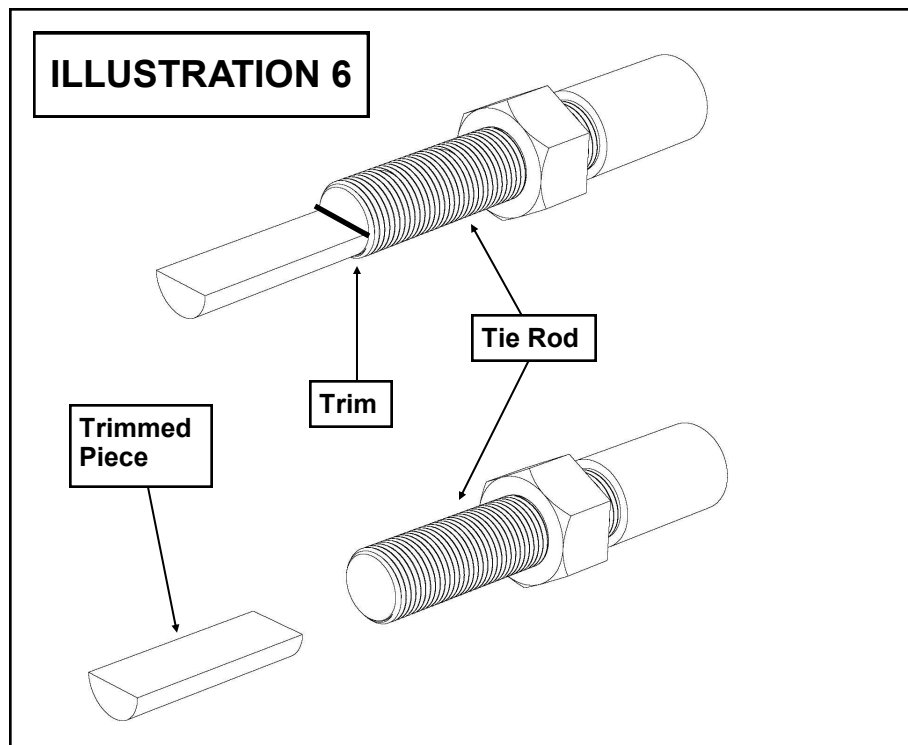

the coil spring may not be right side up.

NOTE: *On the driver side the upper coil spring tail will be closest to the inside of the bucket at the 3 o' clock position. On the passenger side the upper coil spring tail will be closest to the front of the bucket in a 12 o' clock position.*

35. Install your new Pro Comp shocks (927553 w/ shaft up). Install using the previously removed upper hardware and the lower shock bolt. Torque the lower bolt to **60** ft./lbs. See **ILLUSTRATION 5**.
36. Loosen the jam nuts on the tie rod adjustment collar and thread the tie rod out of the collar by spinning the collar until all three pieces are separated.
37. Using a cut off wheel, carefully remove the alignment dowel from both the drag link and tie rod. This will allow you to rotate the tie rod 180 degrees to attach it to the bottom of the new pitman arm. See **ILLUSTRATION 6**.
38. Reassemble the collar, pitman arm, and drag link.

39. Rotate the tie rod at the pitman arm **180 degrees** and attach it to the bottom of the new pitman arm. Torque nut to **45** ft./lbs.
40. Install the sway bar drop brackets (**91-9523** **drv** and **91-9526** **pass**) to the original sway bar mounting holes in the frame using the previously removed **OE** bolts. Torque to **45** ft./lbs. See **ILLUSTRATION 7**.

IMPORTANT: *Be sure that the drop brackets are offset toward the front of the vehicle.*

41. Raise the sway bar mount brackets to the drop bracket (**91-9523** **drv** and **91-9526** **pass**) and secure using the supplied **7/16"** hardware from pack (**90-6340**). Torque the hardware according to the torque chart on page 15. See **ILLUSTRATION 7**.
42. Repeat on the other side of the vehicle.
43. Bolt the front brake line tabs (**90-9528** **Drv** and **90-9529** **Pass**) to the original **OE** brake line bracket holes, on the front axle brackets, using the **8mm** clip-on nuts and previously removed **OE** bolts. See **ILLUSTRATION 8**.

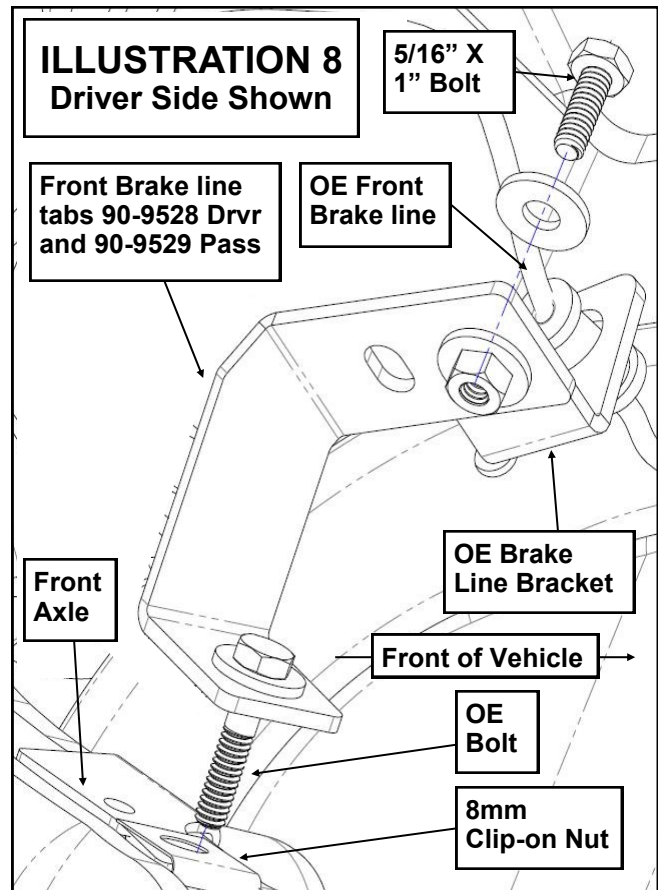
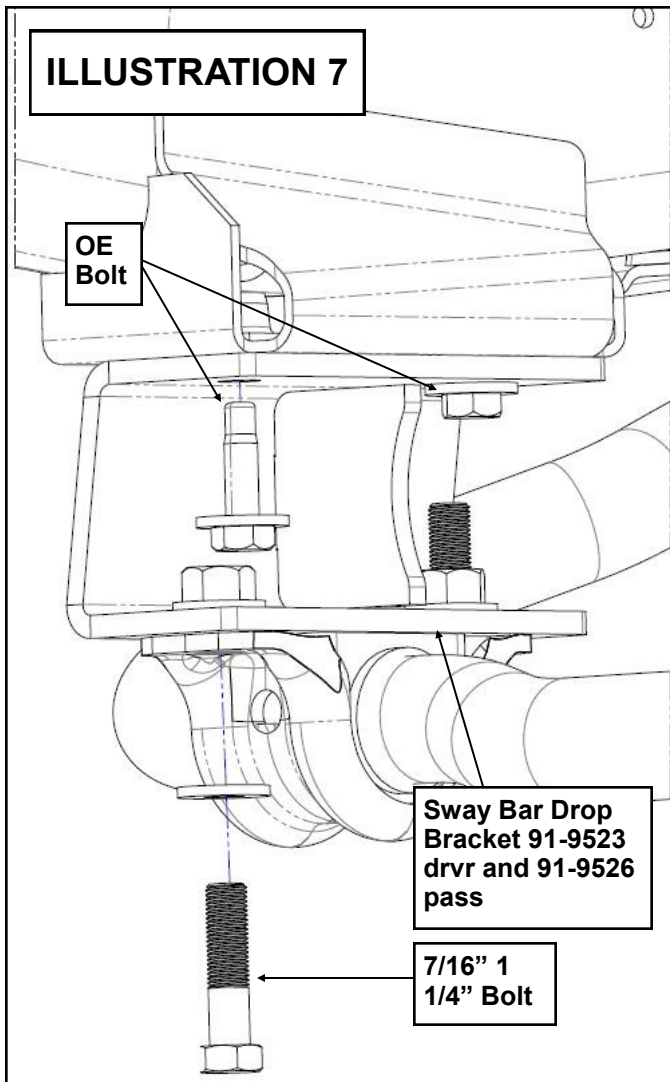

NOTE: Spacer (35-10918) is only used if the vehicle is not equipped with a RAM R46 recall bracket.

44. Secure the **OE** brake lines to the front brake line tabs (**90-9528 Drvr** and **90-9529 Pass**) using the supplied **5/16" X 1"** bolt and hardware. See **ILLUSTRATION 8**.
45. Open up the access hole, in the **OE** frame crossmember access hole, closest to the driver side frame rail to **3/4"** or larger.
46. Remove the rear **OE** steering box bolt
47. Install the track bar drop bracket (**91-10914**) into place. Insert the track bracket sleeve (**90-8321**) inside the frame mounting bracket and the spacer (**35-10918**) in between the frame mounting pocket and the track bar bracket and install the **18mm X 100mm** bolt provided in the upper hole. See **ILLUSTRATION 9**.

48. Reinstall the previously removed **OE** steering box bolt. See **ILLUSTRATION 9**.
49. Using the **(2)** holes in the track bar drop bracket (**91-10914**) as a guide and drill through the track bar drop bracket to enlarge the **(2)** holes in the frame crossmember. See **ILLUSTRATION 9**.
50. Install the **3/8"** double nut plate (**91-9536**) through the previously drilled out access hole in the frame crossmember.
51. Secure the **(2)** remaining holes in the track bar drop bracket to the frame and **3/8"** double nut plate (**91-9536**) using the **(2)** supplied **3/8" X 1 1/4"** bolts and **3/8"** hardware. See **ILLUSTRATION 9**.
52. Torque the track bar drop mounting hardware according to the chart on page **19**. Torque the **18mm X 100mm** bolt to **175** ft./lbs. See **ILLUSTRATION 9**.

ILLUSTRATION 9

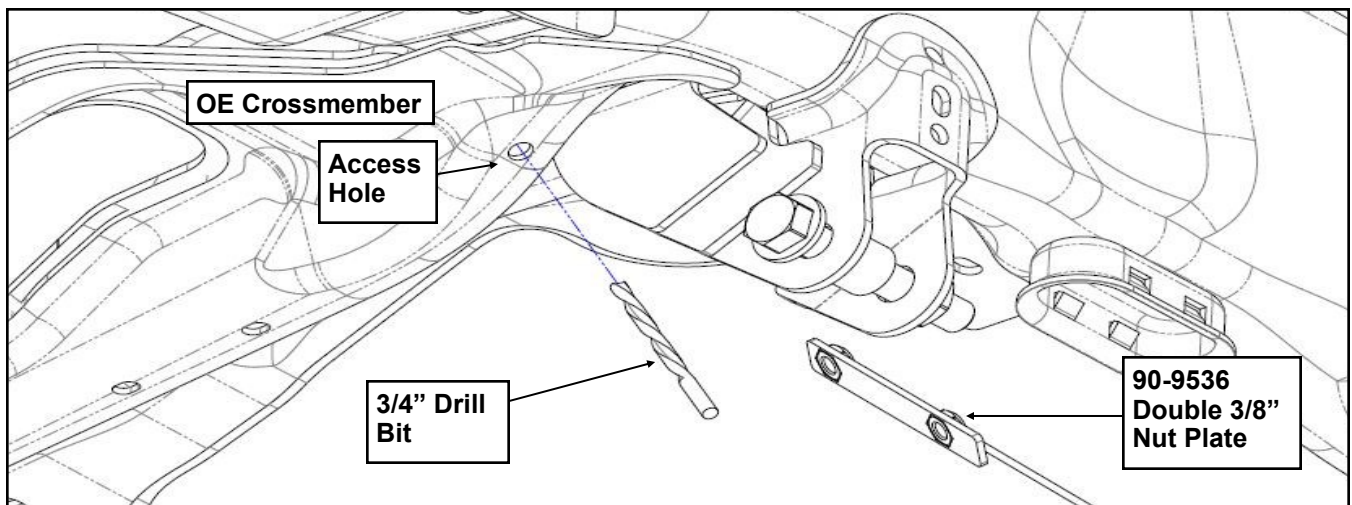
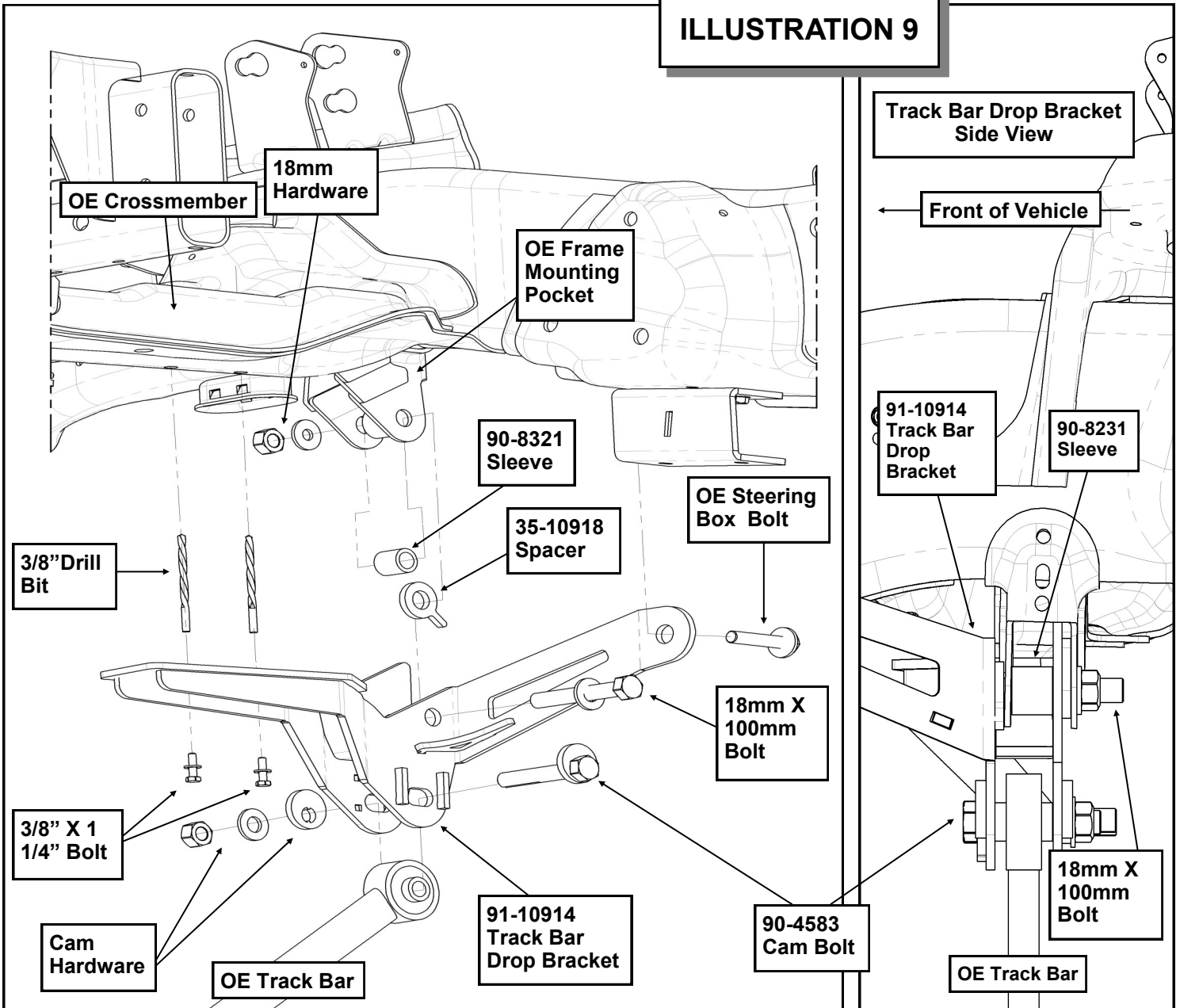

NOTE: Be sure to use thread locker on these bolts.

53. Reinstall the **OE** track bar using the previously removed **OE** hardware at the axle end and the new adjustable cam bolt (**90-4583**) and cam hardware from hardware pack (**90-6956**) in the track bar drop bracket end (**91-10914**). Be sure to install the cam with the head of the bolt facing the front of the vehicle. Do not torque the cam bolt at this time. **See ILLUSTRATION 9.**
54. Install your wheels and tires and lower the vehicle to the ground. Tighten the lug nuts to **90** ft./lbs.
55. Torque the control arms to specifications chart in the rear of the instructions.
56. With the vehicle on the ground, measure from the outside edge of the tires to the edge of the wheel well on the fenders. Use the cam bolt (**90-4583**) to center the axle under the vehicle by rotating the cam until the measurement is equal on both sides. Torque the cam bolt to **150** ft./lbs. **See ILLUSTRATION 9.**
57. With the vehicle on the ground, re-attach sway bar to the sway bar end links using the previously removed **OE** hardware. Torque **OE** sway bar hardware according to manufacturers specifications and the **7/16"** hardware to **60** ft./lbs. **See ILLUSTRATION 7.**
58. On both sides of the vehicle, check the routing of the brake lines and the ABS wire harnesses. There must be no pinching, rubbing, or stretching of any component. Use zip ties to secure these items out of the way of the steering components. At full droop, cycle the steering from lock to lock while observing the reaction of these components. Reposition them if needed.
59. Recheck for proper installation and torque, of all of the newly installed hardware and after any off road use.
60. Have your vehicle aligned as soon as possible.
61. Have your headlights adjusted.
62. After 100 miles recheck for proper torque on all newly installed hardware.

Rear Installation

1. Block the front tires and raise the rear of the vehicle. Support the frame with jack stands forward of the rear springs.
2. Remove the wheels and tires.
3. Remove the **OE** bump stop from the frame.
4. Remove the shocks on both sides of the vehicle. It may be necessary that you slightly raise the axle to unload the shocks for removal. Save the hardware for reinstallation.
5. Disconnect the sway bar end links and remove them from the vehicle. The end links will not be reused.
6. Unbolt the track bar from the rear axle mount and secure up and out of the work area. Save the hardware for reinstallation.
7. Carefully lower the rear axle enough to remove the coil springs from the rear spring seats. Remove and save the **OE** isolators for reinstallation. Make certain the spring seats are free of any weld splatter to ensure proper installation of the rear coil spacer brackets (**91-9555** **drv** and **91-9561** **pass**).
8. **ON DRIVER SIDE ONLY**, Install the rear coil spacer bracket (**91-9555**) using (2) **3/8" X 1 1/4"** bolt and hardware through the top of the **OE** spring seat. See **ILLUSTRATION 10**. Rest the **OE** track bar above it's original position and proceed to step 9.
9. Install the rear track bar relocation bracket (**91-9554**) inside the **OE** track bar mount using the (2) **7/16" X 1 1/4"** bolts and hardware through the side holes and (1) **3/8" X 1"** bolt through the top to secure the rear track bar relocation bracket to the rear coil spacer bracket (**91-9555**). Install the **OE** track bar mounting bolt through the upper hole in the rear track bar relocation bracket and the **OE** track bar. Secure using the **OE** nut plate. **DO**

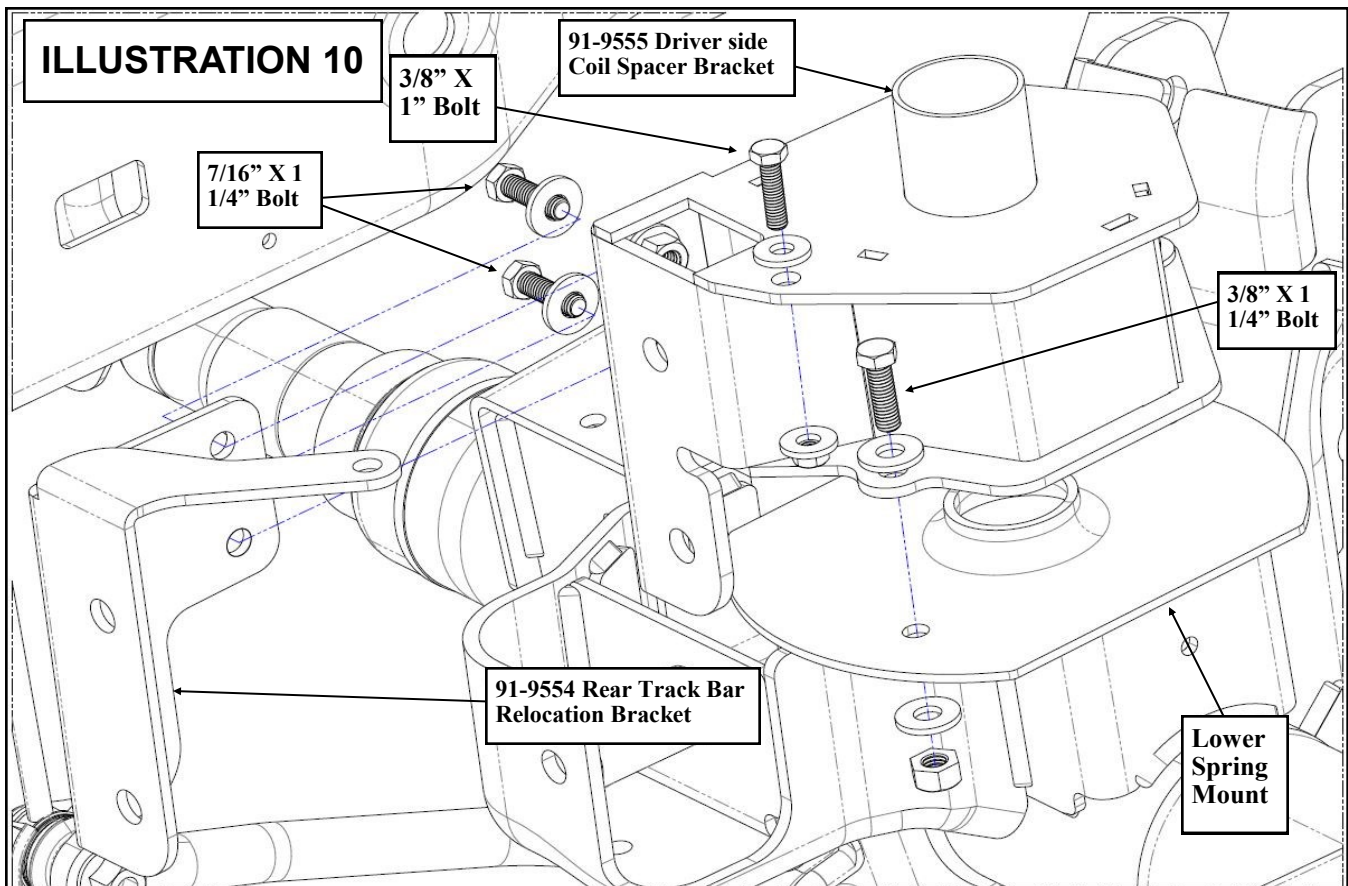

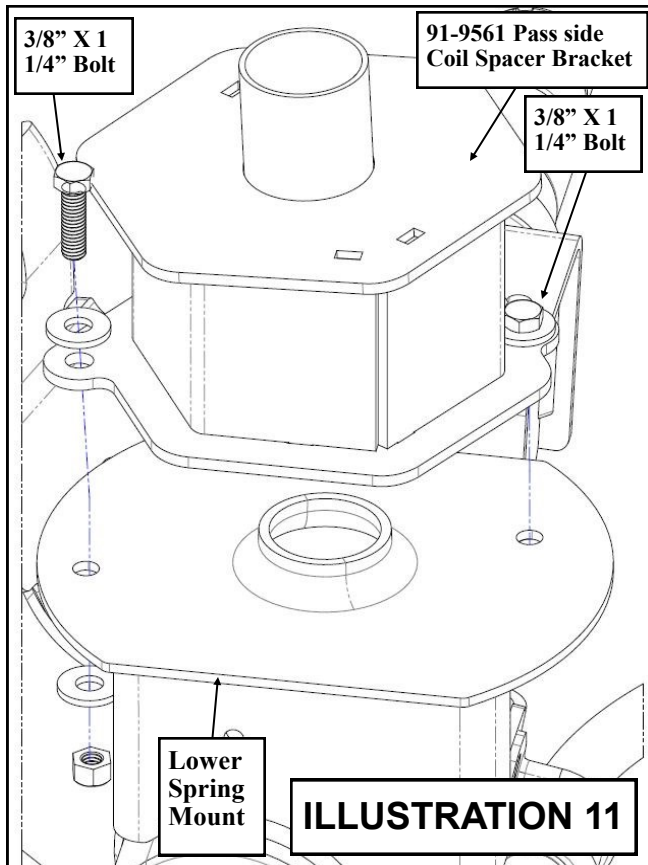

NOT torque hardware at this time. Place sleeve (90-8322) inside OE track bar mount and install the supplied 9/16" X 4" bolt through the OE track bar mount, track bar relocation bracket and sleeve with 9/16" washer and nut. See ILLUSTRATION 12.

10. **ON PASSENGER SIDE ONLY**, Install the rear coil spacer bracket (91-9561), with the shorter side facing forward, using (2) 3/8" X 1 1/4" bolt and hardware through the top of the OE spring seat. See ILLUSTRATION 11.
11. Torque all the coil spacer bracket (91-9555 **drv** and 91-9561 **pass**) and track bar relocation bracket (91-9554) hardware according to the torque chart on page 19.
12. Install the previously removed OE lower spring isolators on top of the rear coil spacer brackets (91-9555 **drv** and 91-9561 **pass**). Spacers (91-9566 2 per side) can be installed below the OE iso-

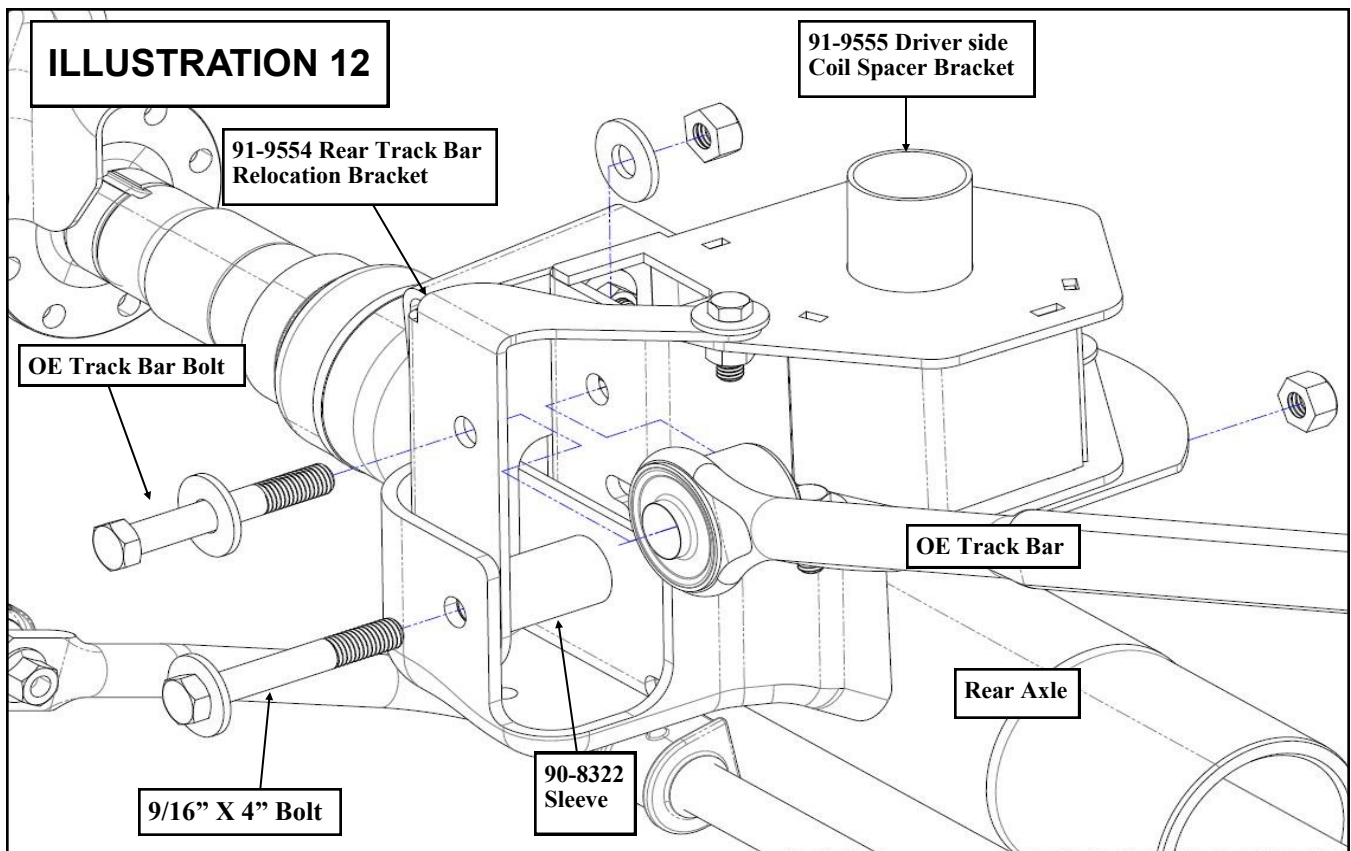

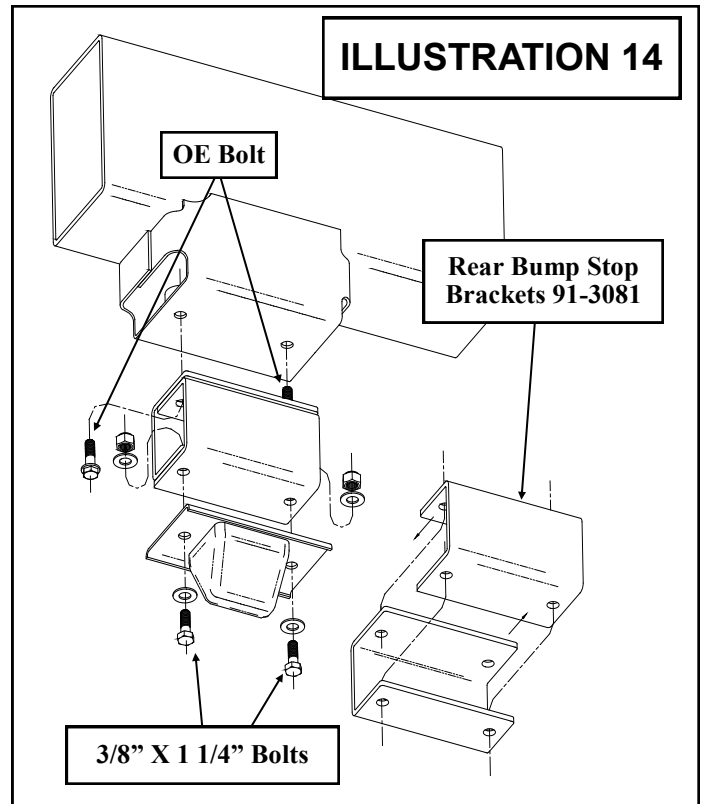
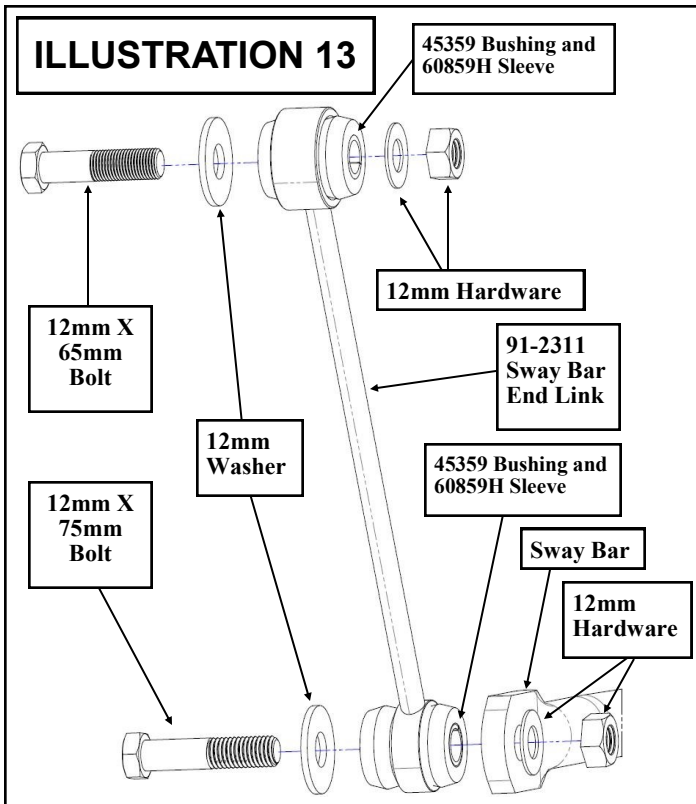

lators for a 1/2" height increase. Carefully lower the rear axle to allow installation of the **OE** coil springs with the **OE** upper isolators. Raise the rear axle and make sure the coil springs seat properly.

13. Assemble the rear sway bar end links (**91-2311**) using the supplied bushings (**45359**) and sleeves (**60859H**). See **ILLUSTRATION 13**.
14. Install the rear sway bar end link (**91-2311**) upper ends into original mounting brackets on the frame. Secure using the supplied **12mm X 65mm** bolts and **12mm** flat washers. Torque according to factory specifications. See **ILLUSTRATION 13**.
15. Secure the lower end link mounts to the sway bar using the supplied **12mm X 75mm** bolts and **12mm** flat washers. Torque according to the torque chart on page **19**. See **ILLUSTRATION 13**.
16. Assemble the rear bump stop brackets (**91-3081**) together as shown in **ILLUSTRATION 14**. Then secure to the frame using the previously removed **OE** bolts.

17. Using the **3/8" X 1 1/4"** bolts and hardware from pack (**90-6223**) bolt the bump stop to the brackets. As shown in **ILLUSTRATION 14**.
18. Install your new Pro Comp rear shocks (**926553 w/ shaft up**) and torque hardware to **60 ft./lbs**.
19. On both sides of the vehicle, check the routing of the brake lines and the ABS wire harnesses. There must be no pinching, rubbing, or stretching of either component. If necessary use zip ties to secure these lines out of the way and to keep from contacting any moving parts. Reposition them if needed.
20. Reinstall the wheels and tires and lower the vehicle to the ground. Torque the lug nuts to manufacturers specifications.
21. Torque the **OE** track bar axle mounting bolt to **130 ft./lbs**.
22. Recheck the wheel lug torque on all four wheels at this time.
23. Recheck all hardware for proper installation and torque at this time.

NOTES:

- ⇒ **After 100 miles recheck for proper torque on all newly installed hardware.**
- ⇒ **Have your headlights adjusted.**
- ⇒ **Recheck all hardware for tightness after off road use.**

MODIFICATION PAGE:

8.7.14: Updated kit fitment box to 2014 and Dodge to Ram.

4.15.15: Changed Pitman arm torque values to 225 ft.lbs.

1.23.16: Added coil spring drill template instructions for proper spring re-indexing.

1.23.16:: Updated illustrations 5 and 8.

8.13.16: Removed track bar drop bracket 91-9530, added track bar drop bracket 91-10914, and added track bar bracket spacer 35-10918 to BOM box-2. Updated illustrations 9.

8.28.16: Updated 6" diesel and gas front coil spring part numbers.

9.8.16: Added recall R46 note to page 12.

9.21.16: Updated fitment years on cover.

8.25.21: Added T/M instance to K2197/K2198. Carried over instructions from K2097/K2098.

Bolt Torque and ID						
Decimal System			Metric System			
All Torques in Ft. Lbs.						
Bolt Size	Grade 5	Grade 8	Bolt Size	Class 9.8	Class 10.9	Class 12.9
5/16	15	20	M6	5	9	12
3/8	30	45	M8	18	23	27
7/16	45	60	M10	32	45	50
1/2	65	90	M12	55	75	90
9/16	95	130	M14	85	120	145
5/8	135	175	M16	130	165	210
3/4	185	280	M18	170	240	290

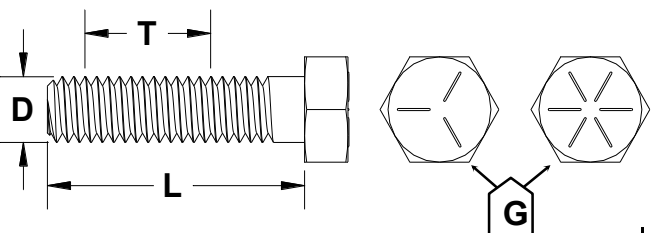
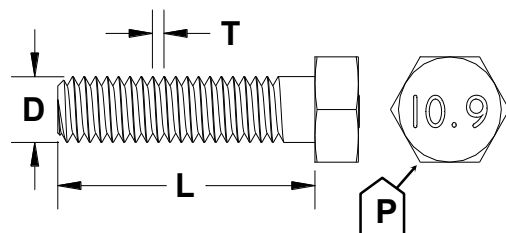
 <p style="text-align: center;">1/2-13x1.75 HHCS</p> <div style="display: flex; justify-content: space-around;"> <div style="text-align: center;"> <p>Grade 5</p> <p>(No. of Marks + 2)</p> </div> <div style="text-align: center;"> <p>Grade 8</p> <p>(No. of Marks + 2)</p> </div> </div> <div style="display: flex; justify-content: space-around; margin-top: 10px;"> <div style="text-align: center;">D</div> <div style="text-align: center;">T</div> <div style="text-align: center;">L</div> <div style="text-align: center;">X</div> </div>	 <p style="text-align: center;">M12-1.25x50 HHCS</p> <div style="display: flex; justify-content: space-around; margin-top: 10px;"> <div style="text-align: center;">D</div> <div style="text-align: center;">T</div> <div style="text-align: center;">L</div> <div style="text-align: center;">X</div> </div>
--	--

<p>G = Grade (Bolt Strength)</p> <p>D = Nominal Diameter (Inches)</p> <p>T = Thread Count (Threads per Inch)</p> <p>L = Length (Inches)</p> <p>X = Description (Hex Head Cap Screw)</p>	<p>P = Property Class (Bolt Strength)</p> <p>D = Nominal Diameter (Millimeters)</p> <p>T = Thread Pitch (Thread Width, mm)</p> <p>L = Length (Millimeters)</p> <p>X = Description (Hex Head Cap Screw)</p>
---	--



The PRO COMP PROMISE WARRANTY

At Pro Comp, we know you have many choices when selecting products to personalize your vehicle. You should demand nothing but the highest quality available and have total confidence that the products you selected are the best in the industry. It is for these reasons that Pro Comp Suspension products are backed by the best warranty in the industry...the Pro Comp Promise!

Pro Comp promises that its products will last a lifetime or we will replace it free of charge. It's that simple! Because of our commitment to quality and manufacturing excellence, we are able to stand behind our products. FOREVER.

It is Pro Comp's Promise that if one of our suspension products breaks not due to misuse, neglect or vandalism, we will replace it. Whether you are the original purchaser or not, you can be assured that we will make it right. The Pro Comp Promise covers all suspension products including shocks and steering stabilizers. Buy Pro Comp Suspension today and enjoy it for the rest of your life!

That's our Pro Comp Promise!

Notice to Owner, Operator, Dealer and Installer:

Vehicles that have been enhanced for off-road performance often have unique handling characteristics due to the higher center of gravity and larger tires. This vehicle may handle, react and stop differently than many passenger cars or unmodified vehicles, both on and off-road. You must drive your vehicle safely! Extreme care should always be taken to prevent vehicle rollover or loss of control, which can result in serious injury or even death. Always avoid sudden sharp turns or abrupt maneuvers and allow more time and distance for braking! Pro Comp reminds you to fasten your seat belts at all times and reduce speed! We will gladly answer any questions concerning the design, function, maintenance and correct use of our products.

Please make sure that the Dealer / Installer explains and delivers all warning notices, warranty forms and instruction sheets included with Pro Comp product.

Warranty and Return Policy:

Pro Comp warrants its full line of products to be free from defects in workmanship and materials for the life of the product. Pro Comp's obligation under this warranty is limited to repair or replacement, at Pro Comp's option, of the defective product. Any and all costs of removal, installation, freight or incidental or consequential damages are expressly excluded from this warranty. Pro Comp is not responsible for damages and / or warranty of other vehicle parts related or non-related to the installation of Pro Comp product. A consumer who makes the decision to modify his vehicle with aftermarket components of any kind will assume all risk and responsibility for potential damages incurred as a result of their chosen modifications. Warranty coverage does not include consumer opinions regarding ride comfort, fitment and design. Warranty claims can be made directly with Pro Comp or at any factory authorized Pro Comp dealer.

IMPORTANT! To validate the warranty on this purchase please be sure to mail in the warranty card.

Claims not covered under warranty

* Parts subject to normal wear; this includes bushings, bump stops, ball joints, tie rod ends and heim joints.

* Finish after 90 days.

* Damage caused as a result of not following recommendations or requirements called out in the installation manuals.

Pro Comp MX Series coil-over shocks are considered a serviceable shock with a one-year warranty against leakage only. Rebuild service and replacement parts will be available and sold separately by Pro Comp. Contact Pro Comp for specific service charges. Pro Comp accepts no responsibility for any altered product, improper installation, lack of or improper maintenance or improper use of our products.

E-Mail: info@procompusa.com
Website: www.procompusa.com
Fax: (310) 747-3912
Ph: 1-800-776-0767

PLACE
WARRANTY REGISTRATION
NUMBER
HERE: _____